



Made in the U.S.A.

SERVICE BODIES



Above: Body Shown with Stylized Automotive Door Latch Option.

For the best in quality and durability,
insist on Omaha Standard



America's Standard in Truck Bodies

Omaha Standard E-Coat Paint



All Omaha Standard products are ...

Cleaned and pretreated with a phosphate conversion coating to prepare the product for electrocoating.

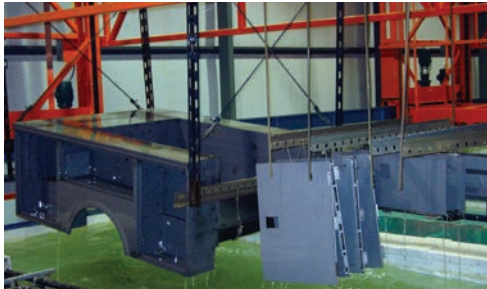

Dipped into a paint bath where direct current is applied between the products and a counter electrode. Paint is attracted by the electric field to the product and is deposited onto the product.



Removed from the bath and rinsed to reclaim undeposited paint solids.



Then transferred to the bake oven and completely cured at a temperature of 375°F.

Omaha Standard E-Coat Paint



If Rust is the Problem...

Unlike traditional spray-painting and powder coating that can leave sections of products unprotected, Omaha Standard e-coat completely covers the products to make them more durable and corrosion resistant giving you more value for your money.

E-coat is environment-friendly, recyclable, and economical with the paint applied with a precise thickness over the entire product so no paint is wasted.

E-Coat is the Solution!



Made in the U.S.A.

Good Looking, Hard Working And The Longest Warranty Available In The Industry.

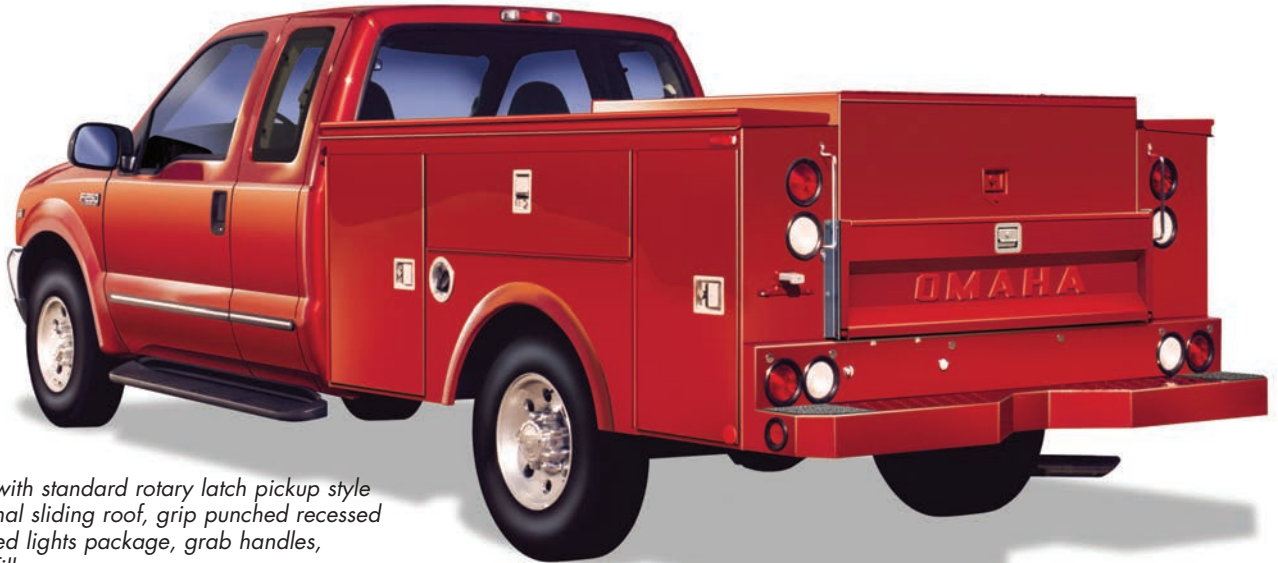

Model 96V shown with standard rotary latch pickup style slam tailgate, optional sliding roof, grip punched recessed bumper with recessed lights package, grab handles, and aluminum fuel fill cup.

The all **galvannealed steel** Omaha Service Body reflects more than 80 years of exceptional truck body building. This know-how combined with superior materials, advanced design and manufacturing processes, and an **epoxy electrocoat primer** result in the best service body on the road today. *And that's why we offer the longest limited warranty in the business---six years on door hinges, door latches, trays, and rust through and three years on all other body components.*

No matter what type of job you need to tackle, we have a service body to fit your needs. Omaha Service Bodies have standard features that make them rugged, long lasting and efficient. And with the many options available, you can custom tailor a body to your specific needs.

STANDARD FEATURES

BODY

- Entire body exterior made from 14-gauge A-40 two sided galvannealed zinc coated steel.
- Complete automotive type undercoating of body underside for total rust protection.
- Distinctive die-formed automotive style fender provides tire clearance for all truck applications.
- Heavy duty treadplate steel flooring with drain openings at base of bulkhead. 3/16" floor optional.



Automotive style fender

TAILGATE

- Pickup style slam tailgate.

BODY SUBSTRUCTURE

- 7 Gauge steel channel front and rear cross members.
- 7 Gauge intermediate cross members which rest on truck frame for added strength.
- 4-14 Gauge horizontal floor stiffeners interlaced with cross members giving added strength in critical areas at rear of body and in wheel well area.



"V" CONFIGURATION

"V" Configuration with two full height vertical compartments



"H" CONFIGURATION

"H" Configuration with long horizontal compartment



OPTIONAL TOP OPENING

- Automotive type gas shocks hold top open
- Weather tight seal
- 15 adjustable dividers
- Opening latch accessed inside horizontal compartment

Matches Or Exceeds Truck Manufacturers' Warranties

| | |
|--|--|
| 6 YEAR LIMITED WARRANTY Hinges, Latches, Trays and Rust Through | 3 YEAR LIMITED WARRANTY All Other Body Components |
|--|--|

In the interest of product improvement, Omaha Standard Inc. reserves the right to modify, change or revise design and specifications and furnish product so altered without prior notice.



Made in the U.S.A.

COMPARTMENT OPTIONS



Single slide out trays available in 150 or 250 lbs. capacity. Horizontal door with heavy duty cable retainers provides a smooth, level work surface.



Nested slide out trays—shown closed. Available with 150 and 250 lb. capacity trays.



Drawer cabinets for horizontal compartments only. Available with 6, 12 and 18 drawers. Shown above is the 12-drawer version.



Nested slide out trays—shown open. Available in 3, 4, or 5-tray sets. Tray dividers optional.

STANDARD COMPARTMENT FEATURES

- Two divider trays in each front vertical compartment.
- One divider tray for the center horizontal compartment in the “V” configuration body.
- 20 galvanized steel tray dividers.
- All trays are galvanized steel.
- One galvanized steel shelf in each rear vertical compartment.
- Compartment interiors are painted light gray for increased illumination. (white paint optional.)

DOORS

- Double panel doors with interior steel “C” channel stiffeners bonded to panels with structured adhesive to eliminate welds.
- Double panel door perimeter is fully bonded with a high strength epoxy to eliminate weld marks.
- Full length all stainless steel hinge with concealed hinge leaves and 1/4” stainless steel pin.
- Door hinges are bolted to door frame for security and ease of replacement.
- All stainless steel automotive rotary paddle latch is standard. Blind bolted to inside of door for ease of replacement.
- Optional stylized black nylon automotive rotary paddle latch to complement truck door handles.
- Adjustable stainless steel door latch striker pin.
- Door channel design diverts water away from door opening to help keep compartments dry.
- Full perimeter structural adhesive bonded automotive neoprene bulb door seals with no break at latch for full weatherproof integrity.
- Spring-loaded over-center door retainers on all full-size vertical doors.

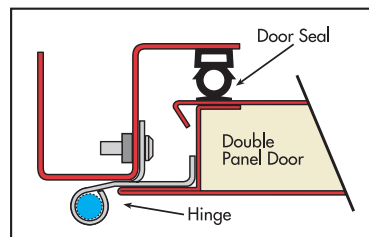

Full perimeter automotive neoprene bulb door seal attached with structural adhesive backing.



Compartment shelves are flat with a 1” flange that can be installed in the compartment flange up or down.

RAISED COMPARTMENT



Front raised compartment shown with trays and a 3-point “T-handle” latch, the only latch offered for raised compartments.

Compartment can also be upfitted with gas bottle retainers and louvered vents in the compartment door.

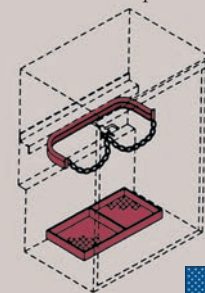

Gas bottle retainers for torch or welder.



Made in the U.S.A.

THRU COMPARTMENTS

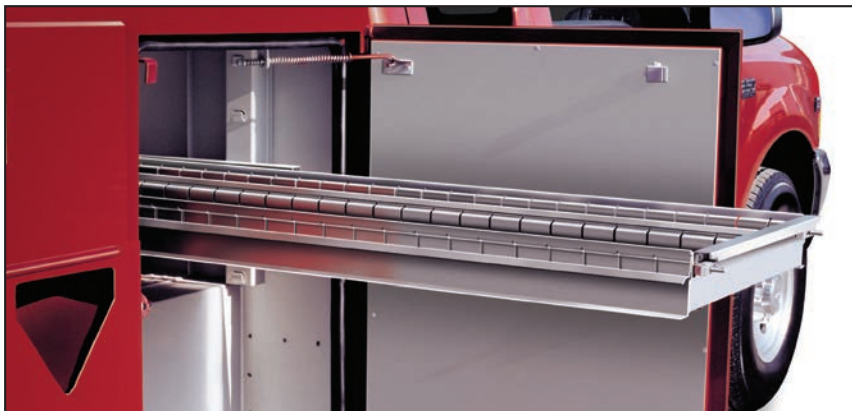

- Thru compartments for protected storage of generators, small welders etc.
- Roll out trays (up to 4) can be installed and pull out to curbside or streetside.
- Heavy-duty nylon rollers allow the trays to roll with ease.
- 3/4 thru compartment pulls out one side only (curbside recommended).

Optional wheel chock holder in body shown at left

BUMPER AND TAILGATE

Pickup Style Slam Tailgate

Non-slip Pads Standard On Grip Punch Bumpers Only

Optional Galvanized Steel Grip Punch Recessed Bumper

Optional Stylized Black Nylon Automotive Rotary Paddle Latches Complement Truck Door Handles

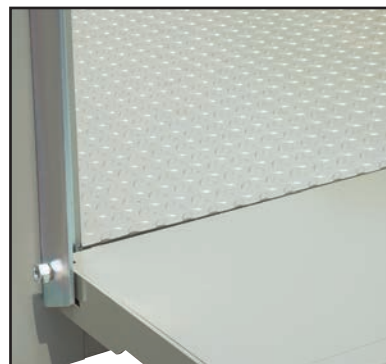

The standard "Pickup Style Slam Tailgate" allows for one hand operation.

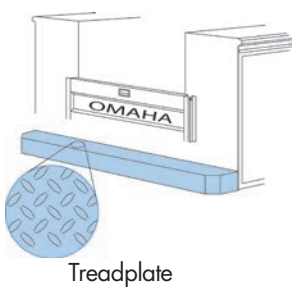

Treadplate



Hinged cover for recessed bumpers

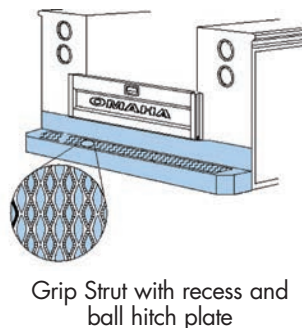

Grip Strut with recess and ball hitch plate

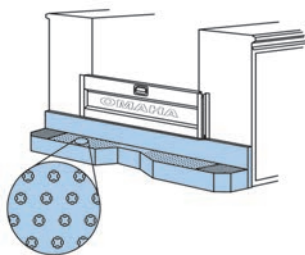

Grip Punch with recess

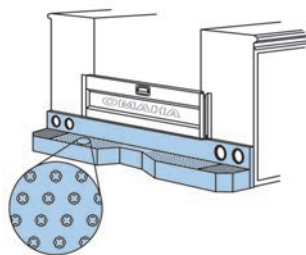

Grip Punch with recessed lights

BUMPER STYLES

Choose from five different bumper styles, three different surfaces and an optional recessed lights package.

Grip punch bumpers are 12 gauge A-40 two sided galvanized steel.

Matches Or Exceeds Truck Manufacturers' Warranties

6 YEAR LIMITED WARRANTY
Hinges, Latches, Trays and Rust Through

3 YEAR LIMITED WARRANTY
All Other Body Components

In the interest of continuing product improvement, Omaha Standard Inc. reserves the right to modify, change or revise design and specifications and furnish product so altered without prior notice.



Made in the U.S.A.

HIROOF MODELS



Full width HiRoof

HiRoof models are available in 54", 60" and 72" floor to ceiling heights. The 54" and 60" models have two shelves per side. The 72" model has three shelves per side. Compartment interiors and cargo area painted gray for increased illumination. White paint optional. Optional skylights are available. HiRoofs are ideal for interior work and secure cargo space.



- Constructed from heavy duty 14 and 16 gauge two sided zinc coated galvanized steel.
- Rear door panels are double panel 18 gauge two sided galvanized steel with interior steel channel stiffeners bonded between panels.
- Rear doors feature 2-point paddle latch with top and bottom rotary latches, full length hinges, over center spring door retainers and 9"x 34" safety glass in each door.
- Bulkhead window is 14" x 30" safety glass.



The Omaha Service Vehicle ("OSV") for cutaway chassis is also available...contact your distributor for all the details and specifications.

Matches Or Exceeds Truck Manufacturers' Warranties

| | | | |
|----------|--|----------|--|
| 6 | YEAR LIMITED WARRANTY Hinges, Latches, Trays and Rust Through | 3 | YEAR LIMITED WARRANTY All Other Body Components |
|----------|--|----------|--|

In the interest of continuing product improvement, Omaha Standard Inc. reserves the right to modify, change or revise design and specifications and furnish product so altered without prior notice.

HIROOF OPTIONS

- Sliding roof (in lieu of fixed roof) models have full length rain trough and Teflon slide pads.
- Weather tight rubber mounted skylight windows.
- Doors in side panels for exterior access.
- Dome lights with rear mounted switch.
- Extra interior shelving.
- Fully enclosed interior storage compartments with interior access doors.
- Window guards for bulkhead and rear windows.
- Sliding glass in bulkhead window.
- Hot stick box with access door.



HiRoof with 5" offset from outside edge of the body



Made in the U.S.A.

SLIDING ROOFS



Sliding roofs provide theft protection and a weather-tight seal. The 96" and 108" bodies have a 2-piece sliding roof; the 132" has a 3-piece design.

- Constructed entirely of A-40 two-sided galvanized steel.
- Sliding roofs feature a 2-point "T" handle lock.
- The roof glides on Teflon pads.

End panel is hinged and swings open to lay on roof top; roof top slides toward the cab for a wide open work space.



TREADPLATE OVERLAYS

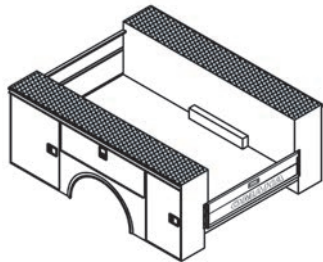

Compartment Tops

Treadplate steel or treadbrite aluminum overlays give extra strength and durability to your Omaha Service body. Add the 12 gauge treadplate overlay to the sections of your service body that receive the toughest treatment to help eliminate dings or dents. 6000 pound crane bodies are built with treadplate overlays as standard.

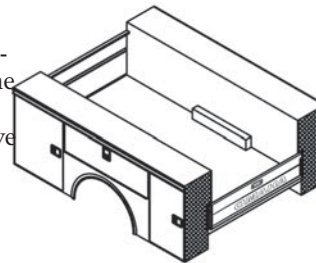

Compartment Rear End Panels

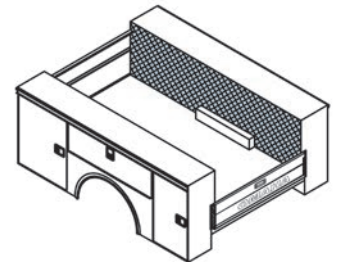

Inside of Load Space

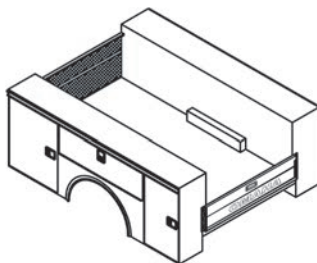

Inside Front

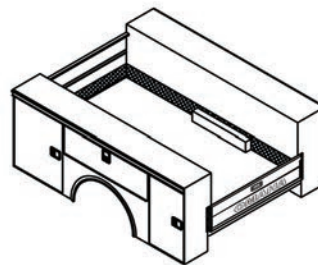

Scuff Plate

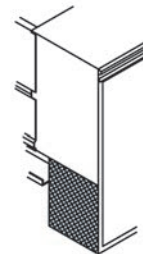

Front Compartment Rock Guard

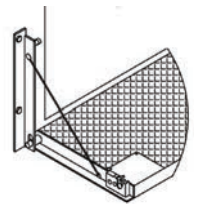

Inside of Tailgate

COMPARTMENT DOOR LATCHES AND LOCKS

Paddle Latches

Heavy duty stainless steel automotive rotary paddle latches combined with adjustable striker pin provide positive door closure. Paddle latches are key lockable and are "blind" bolted to door for security and ease of replacement.



Electro-Mechanical Door Lock System (EML)

The Electro-Mechanical Door Lock System is a wireless security system that includes black stylized latches, actuators, wiring harness, and RF module installed, plus two key fobs. The system provides minimal compartment intrusion and, since the actuators are door frame mounted, there is easy component access and no compartment interference. This system is available factory installed, for retrofitting or shipped loose.

Master Locking System

The Master Locking System will lock all compartments on each side of the body with just a quarter turn of the T-handle. Locks with a key or, for additional security, a padlock (not included) can be used.

Compartment T-Handle Lock

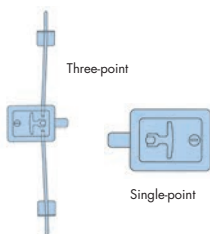

Single and three-point "T" handle locks available in stainless steel. These are tamper proof keyed locks with full weather sealed housing and are adjustable.



Stylized Automotive Latches

The optional Stylized Black Nylon Automotive Rotary Paddle Latches are available factory installed or for retrofitting. The latches complement the factory look of the truck door handles.



LADDER RACKS

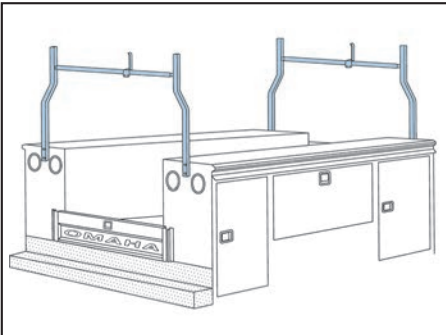

Adjustable Overhead Ladder Rack

Fits all body widths and adapts for both horizontal and vertical taillights.

Includes:

- 4 vertical supports of 1/4" square tube
- 2 cross tubes of 1" structural pipe
- 2 ladder guides
- Mounting hardware
- 2 rubber tie-downs 18" long

Optional guide rails, guide rollers and spring loaded hold downs are available.

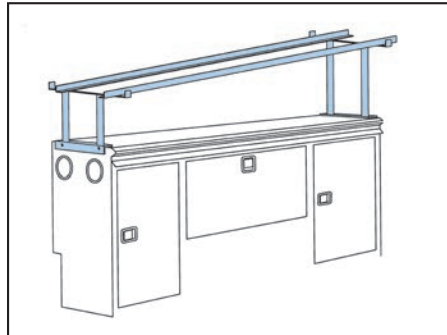

Sloping Top Mount Ladder Rack

Designed to clear truck cab.

Includes:

- 2 vertical support assemblies
- 2 guide rails
- Mounting hardware
- 2 rubber tie-downs 18" long

Optional guide rollers or spring loaded hold downs are available.

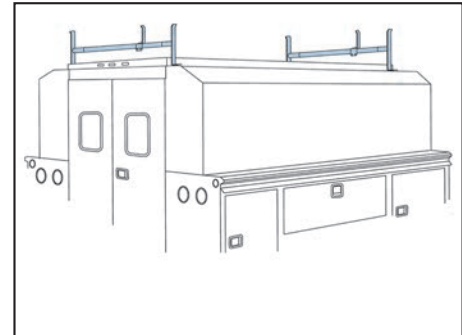

HiRoof Adjustable Overhead Ladder Rack

Fits all body widths.

Includes:

- 4 vertical support assemblies
- 2 cross tubes of 1" structural pipe
- 2 ladder guides
- Mounting hardware
- 2 rubber tie-downs 18" long

Optional guide rails, guide rollers and spring loaded hold downs are available.

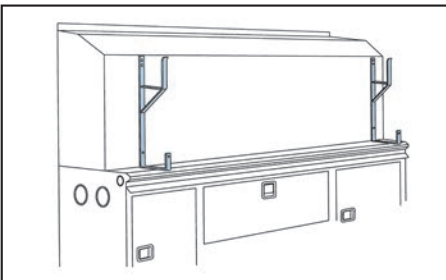

HiRoof Side Mounted Ladder Rack

Includes:

- 2 rack assemblies
- Mounting hardware
- 2 rubber tie-downs 18" long

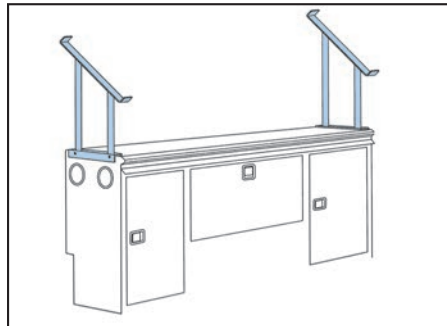

Standard Compartment Top Rack

Designed to clear the truck cab.

Includes:

- 2 rack assemblies
- Mounting hardware
- 2 rubber tie-downs 18" long

Optional guide rails, guide rollers and spring loaded hold downs are available.

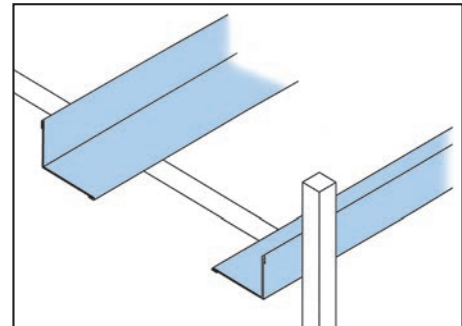

Ladder Rack Guide Rails

For use with overhead racks and compartment top mount rack.

Includes:

- 2 guide rails
- Mounting hardware

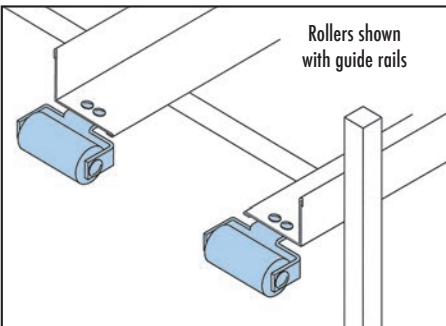

Ladder Rack Guide Rollers

For use with overhead racks, compartment top rack and sloping top mount rack.

Includes:

- 2 roller assemblies
- Mounting hardware

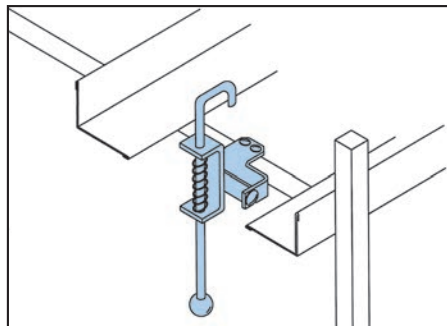

Spring Loaded Hold Downs

For use with overhead racks, compartment top rack and sloping top mount rack.

Includes:

- 2 hold down assemblies
- Mounting hardware

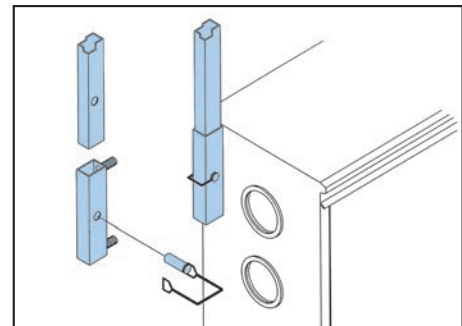

Quick Removal Brackets

For use with overhead rack, compartment top and sloping ladder rack.

Includes:

- 4 quick removal mounts
- Mounting hardware



Made in the U.S.A.

Matches Or Exceeds Truck Manufacturers' Warranties

| | | | |
|----------|---|----------|---|
| 6 | YEAR LIMITED WARRANTY Hinges, Latches, Trays and Rust Through | 3 | YEAR LIMITED WARRANTY All Other Body Components |
|----------|---|----------|---|

This service body is designed for full size and compact Ford single wheel trucks and Chevrolet and Dodge single wheel trucks. The standard compartments are 15" deep on both 72" and 80" bodies. 72" bodies have 38½ floors as standard, and 80" have 48½" wide floors as standard. Standard heights are 40". Low profile models are 36" and top opening models are 38" high. This service body is only available in the "V" configuration for both street and curb side.



STANDARD MODELS

| MODEL | BODY LENGTH | CAB-TO AXLE (CA) | HEIGHT | FLOOR WIDTH | COMPARTMENTS | | EXT. COMP. DEPTH | OVERALL WIDTH | APPROX. WEIGHT (LBS.) |
|-------|-------------|---------------------|--------|-------------|--------------|-----------|------------------|---------------|-----------------------|
| | | | | | STREET SIDE | CURB SIDE | | | |
| 80V | 80" | 40" Ford Full Size | 40" | 48½" | V | V | 15" | 79¾" | 778 |
| 80V | 80" | 42" Chevy Full Size | 40" | 48½" | V | V | 15" | 79¾" | 778 |

LOW PROFILE MODELS

| | | | | | | | | | |
|--------|-----|-----------------------|-----|------|---|---|-----|------|-----|
| 80LPV | 80" | 40" Ford Full Size | 36" | 48½" | V | V | 15" | 79¾" | 778 |
| 80LPV | 80" | 42" Chevy Full Size | 36" | 48½" | V | V | 15" | 79¾" | 778 |
| 76LPV | 76" | 36.9" Dodge Full Size | 36" | 48½" | V | V | 15" | 79¾" | 727 |
| 72LPV* | 72" | 37.6" Ford Ranger | 36" | 38½" | V | V | 15" | 69¾" | 675 |

TOP OPENING COMPARTMENT MODELS

| | | | | | | | | | |
|-------|-----|-----------------------|-----|------|---|---|-----|------|-----|
| 80VT | 80" | 40" Ford Full Size | 38" | 48½" | V | V | 15" | 79¾" | 910 |
| 80VT | 80" | 42" Chevy Full Size | 38" | 48½" | V | V | 15" | 79¾" | 910 |
| 76VT | 76" | 36.9" Dodge Full Size | 38" | 48½" | V | V | 15" | 79¾" | 845 |
| 72VT* | 72" | 37.6" Ford Ranger | 38" | 38½" | V | V | 15" | 69¾" | 780 |

* Not available for Chevrolet Colorado, as the body exceeds GVWR (gross vehicle weight rating)

72V FORD RANGER

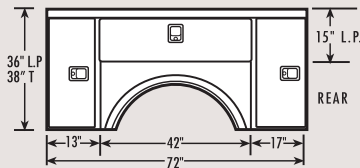

"V" CONFIGURATION-CLEAR DOOR OPENINGS

| COMPARTMENT | STANDARD | LOW PROFILE/TOP OPEN |
|-------------|----------|----------------------|
| Front | N/A | 7¾" w x 30" H |
| Horizontal | N/A | 39½" w x 10" H |
| Rear | N/A | 11¾" w x 30" H |

76V DODGE FULL SIZE

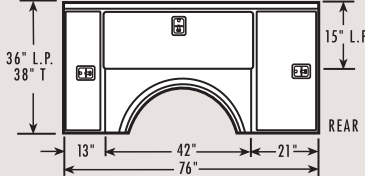

"V" CONFIGURATION-CLEAR DOOR OPENINGS

| COMPARTMENT | STANDARD | LOW PROFILE/TOP OPEN |
|-------------|----------|----------------------|
| Front | NA | 7¾" w x 30" H |
| Horizontal | NA | 39½" w x 10" H |
| Rear | NA | 15¾" w x 30" H |

80V FORD FULL SIZE

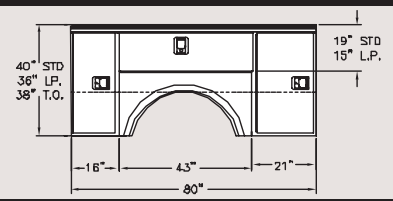

"V" CONFIGURATION-CLEAR DOOR OPENINGS

| COMPARTMENT | STANDARD | LOW PROFILE/TOP OPEN |
|-------------|----------------|----------------------|
| Front | 10¾" w x 34" H | 10¾" w x 30" H |
| Horizontal | 43½" w x 14" H | 40½" w x 10" H |
| Rear | 15¾" w x 34" H | 15¾" w x 30" H |

80V CHEVROLET FULL SIZE

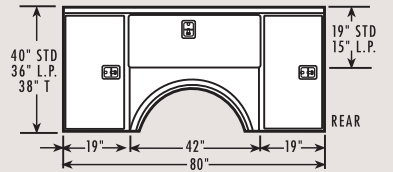

"V" CONFIGURATION-CLEAR DOOR OPENINGS

| COMPARTMENT | STANDARD | LOW PROFILE/TOP OPEN |
|-------------|----------------|----------------------|
| Front | 13¾" w x 34" H | 13¾" w x 30" H |
| Horizontal | 39½" w x 14" H | 39½" w x 10" H |
| Rear | 13¾" w x 34" H | 13¾" w x 30" H |

"V" Configuration



The 72V, 76V and 80V Model Service Bodies are available only in the vertical compartment configuration for both street side and curb side.

END VIEWS OF BODIES

STANDARD BODIES

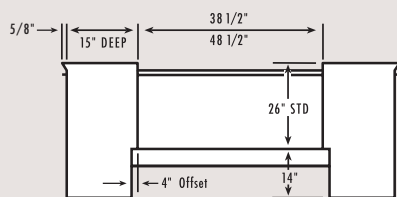

LOW PROFILE AND TOP OPENING BODIES

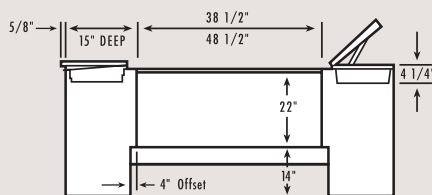

Standard Model Service Bodies include:

- Pickup style slam tailgate
- Stainless Steel rotary paddle latches on all doors
- Automotive door seals in all compartments
- Four (4) trays for front vertical compartments
- One (1) tray for "V" style horizontal compartment
- Galvanized steel tray dividers
- Spring loaded over-center door retainers on Ford rear door and Chevy front and 45 rear full-sized vertical doors
- Cable retainers on small vertical, horizontal and Ford front vertical door
- Cable retainers on curb side and street side horizontal doors
- Bodies are factory prime painted with an gray epoxy electrocoat
- Universal "Quick Mount" mounting kit

Model 80V Service Body shown with optional sliding roof

In the interest of continuing product improvement, Omaha Standard Inc. reserves the right to modify, change or revise design and specifications and furnish product so altered without prior notice.



Matches Or Exceeds Truck Manufacturers' Warranties

| | |
|---|---|
| 6 YEAR LIMITED WARRANTY Hinges, Latches, Trays and Rust Through | 3 YEAR LIMITED WARRANTY All Other Body Components |
|---|---|



Made in the U.S.A.

The popular 8' service body is designed for a single or dual wheel chassis with 56" CA. Single wheel models have 15" deep compartments and 48½" wide floors as standard. Dual wheel bodies have 20" deep compartments and 54½" wide floors. Standard 96" bodies are 40" high, low-profile models are 36" high, and top opening models are 38" high.



STANDARD MODELS

| MODEL | BODY LENGTH | CAB-TO AXLE (CA) | HEIGHT | FLOOR WIDTH | COMPARTMENTS | | EXT. COMP. DEPTH | OVERALL WIDTH | APPROX. WEIGHT (LBS.) |
|---------|-------------|------------------|--------|-------------|--------------|-----------|------------------|---------------|-----------------------|
| | | | | | STREET SIDE | CURB SIDE | | | |
| 96V | 96" | 56" Single Wheel | 40" | 48½" | V | V | 15" | 79¾" | 976 |
| 96VH | 96" | 56" Single Wheel | 40" | 48½" | V | H | 15" | 79¾" | 976 |
| 96H | 96" | 56" Single Wheel | 40" | 48½" | H | H | 15" | 79¾" | 976 |
| 96D54V | 96" | 56" Dual Wheel | 40" | 54½" | V | V | 20" | 95¾" | 1099 |
| 96D54VH | 96" | 56" Dual Wheel | 40" | 54½" | V | H | 20" | 95¾" | 1099 |
| 96D54H | 96" | 56" Dual Wheel | 40" | 54½" | H | H | 20" | 95¾" | 1099 |

LOW PROFILE MODELS

| | | | | | | | | | |
|-----------|-----|------------------|-----|------|---|---|-----|------|------|
| 96LPV | 96" | 56" Single Wheel | 36" | 48½" | V | V | 15" | 79¾" | 934 |
| 96LVH | 96" | 56" Single Wheel | 36" | 48½" | V | H | 15" | 79¾" | 934 |
| 96LPH | 96" | 56" Single Wheel | 36" | 48½" | H | H | 15" | 79¾" | 934 |
| 96LPD54V | 96" | 56" Dual Wheel | 36" | 54½" | V | V | 20" | 95¾" | 1055 |
| 96LPD54VH | 96" | 56" Dual Wheel | 36" | 54½" | V | H | 20" | 95¾" | 1055 |
| 96LPD54H | 96" | 56" Dual Wheel | 36" | 54½" | H | H | 20" | 95¾" | 1055 |

TOP OPENING COMPARTMENT MODELS

| | | | | | | | | | |
|----------|-----|------------------|-----|------|---|---|-----|------|------|
| 96VT | 96" | 56" Single Wheel | 38" | 48½" | V | V | 15" | 79¾" | 1092 |
| 96VHT | 96" | 56" Single Wheel | 38" | 48½" | V | H | 15" | 79¾" | 1092 |
| 96HT | 96" | 56" Single Wheel | 38" | 48½" | H | H | 15" | 79¾" | 1092 |
| 96D54VT | 96" | 56" Dual Wheel | 38" | 54½" | V | V | 20" | 95¾" | 1245 |
| 96D54VHT | 96" | 56" Dual Wheel | 38" | 54½" | V | H | 20" | 95¾" | 1245 |
| 96D54HT | 96" | 56" Dual Wheel | 38" | 54½" | H | H | 20" | 95¾" | 1245 |

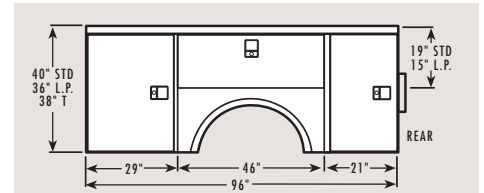

"V" CONFIGURATION-CLEAR DOOR OPENINGS

| COMPARTMENT | STANDARD | LOW PROFILE/TOP OPEN |
|-------------|-----------------|----------------------|
| Front | 23 ¾" w x 34" H | 23 ¾" w x 30" H |
| Horizontal | 43 ½" w x 14" H | 43 ½" w x 10" H |
| Rear | 15 ¾" w x 34" H | 15 ¾" w x 30" H |

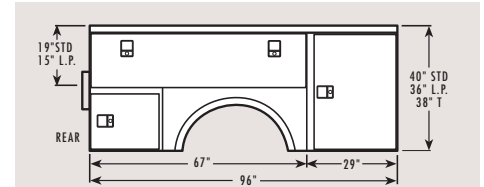

"H" CONFIGURATION-CLEAR DOOR OPENINGS

| COMPARTMENT | STANDARD | LOW PROFILE/TOP OPEN |
|-------------|-------------------|----------------------|
| Front | 23 ¾" w x 34" H | 23 ¾" w x 30" H |
| Horizontal | 63 ¾" w x 14" H | 63 ¾" w x 10" H |
| Bottom Rear | 15 ¾" w x 15 ¾" H | 15 ¾" w x 15 ¾" H |

See End View of bodies on page 11

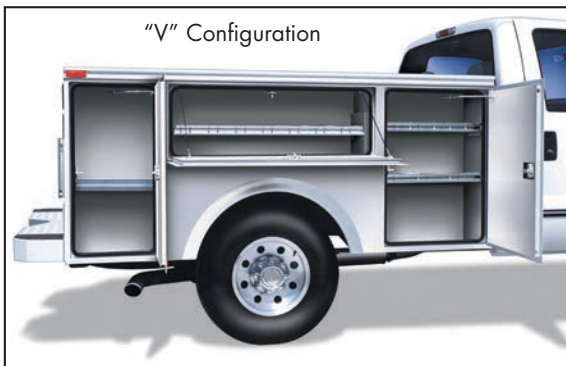

"V" Configuration

"VH" Models are available in reverse configuration: i.e., "H" compartment configuration on the street side and "V" compartment configuration on the curb side. Specify "HV" when ordering. For compartment configuration other than shown, please consult factory.

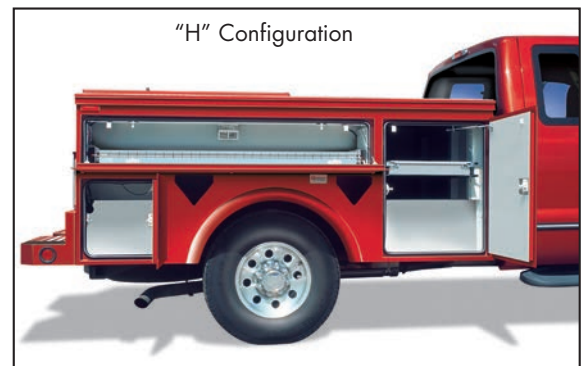

"H" Configuration



Standard Model Service Bodies include:

- Pickup style slam tailgate
- Stainless steel rotary paddle latches on all doors
- Automotive door seals in all compartments
- Four (4) trays for front vertical compartments
- One (1) tray for "V" style horizontal compartment
- Galvanized steel tray dividers
- One (1) shelf in each rear vertical compartment
- Spring loaded over-center door retainers on all full-sized vertical doors
- Cable retainers on small vertical doors on "H" configuration
- Cable retainers on curb side and street side horizontal doors
- Bodies are factory prime painted with gray epoxy electrocoat
- Universal "Quick Mount" mounting kit

Matches Or Exceeds Truck Manufacturers' Warranties

| | | | |
|----------|---|----------|------------------------------|
| 6 | YEAR LIMITED WARRANTY | 3 | YEAR LIMITED WARRANTY |
| | Hinges, Latches, Trays and Rust Through | | All Other Body Components |

In the interest of continuing product improvement, Omaha Standard Inc. reserves the right to modify, change or revise design and specifications and furnish product so altered without prior notice.



Made in the U.S.A.

The 9' service body is designed for a single or dual wheel chassis with 60" CA. Single wheel models have 15" deep compartments with 48½" wide floor as standard. Dual wheel bodies have 20" deep compartments and 48½" or 54½" wide floors. Standard 108" bodies are 40" high, low-profile models are 36" high, and top opening models are 38" high.

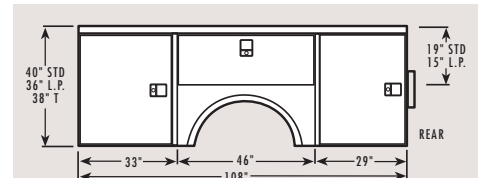

| "V" CONFIGURATION-CLEAR DOOR OPENINGS | | |
|---------------------------------------|-----------------|----------------------|
| COMPARTMENT | STANDARD | LOW PROFILE/TOP OPEN |
| Front | 27 ¾" w x 34" H | 27 ¾" w x 30" H |
| Horizontal | 43 ½" w x 14" H | 43 ½" w x 10" H |
| Rear | 23 ¾" w x 34" H | 23 ¾" w x 30" H |

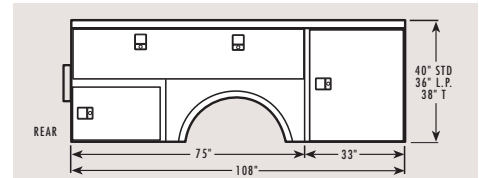

| "H" CONFIGURATION-CLEAR DOOR OPENINGS | | |
|---------------------------------------|-------------------|----------------------|
| COMPARTMENT | STANDARD | LOW PROFILE/TOP OPEN |
| Front | 27 ¾" w x 34" H | 27 ¾" w x 30" H |
| Horizontal | 71 ¾" w x 14" H | 71 ¾" w x 10" H |
| Bottom Rear | 23 ¾" w x 15 ¾" H | 23 ¾" w x 15 ¾" H |

See End View of bodies on page 11

"VH" Models are available in reverse configuration: i.e., "H" compartment configuration on the street side and "V" compartment configuration on the curb side. Specify "HV" when ordering. For compartment configuration other than shown, please consult factory.

STANDARD MODELS

| MODEL | BODY LENGTH | CAB-TO AXLE (CA) | HEIGHT | FLOOR WIDTH | COMPARTMENTS | | EXT. COMP. DEPTH | OVERALL WIDTH | APPROX. WEIGHT (LBS.) |
|----------|-------------|------------------|--------|-------------|--------------|-----------|------------------|---------------|-----------------------|
| | | | | | STREET SIDE | CURB SIDE | | | |
| 108V | 108" | 60" Single Wheel | 40" | 48½" | V | V | 15" | 79¾" | 1098 |
| 108VH | 108" | 60" Single Wheel | 40" | 48½" | V | H | 15" | 79¾" | 1098 |
| 108H | 108" | 60" Single Wheel | 40" | 48½" | H | H | 15" | 79¾" | 1098 |
| 108DV | 108" | 60" Dual Wheel | 40" | 48½" | V | V | 20" | 89¾" | 1181 |
| 108DVH | 108" | 60" Dual Wheel | 40" | 48½" | V | H | 20" | 89¾" | 1181 |
| 108DH | 108" | 60" Dual Wheel | 40" | 48½" | H | H | 20" | 89¾" | 1181 |
| 108D54V | 108" | 60" Dual Wheel | 40" | 54½" | V | V | 20" | 95¾" | 1217 |
| 108D54VH | 108" | 60" Dual Wheel | 40" | 54½" | V | H | 20" | 95¾" | 1217 |
| 108D54H | 108" | 60" Dual Wheel | 40" | 54½" | H | H | 20" | 95¾" | 1217 |

LOW PROFILE MODELS

| | | | | | | | | | |
|------------|------|------------------|-----|------|---|---|-----|------|------|
| 108LPV | 108" | 60" Single Wheel | 36" | 48½" | V | V | 15" | 79¾" | 1051 |
| 108LPVH | 108" | 60" Single Wheel | 36" | 48½" | V | H | 15" | 79¾" | 1051 |
| 108LPH | 108" | 60" Single Wheel | 36" | 48½" | H | H | 15" | 79¾" | 1051 |
| 108LPDV | 108" | 60" Dual Wheel | 36" | 48½" | V | V | 20" | 89¾" | 1133 |
| 108LPDVH | 108" | 60" Dual Wheel | 36" | 48½" | V | H | 20" | 89¾" | 1133 |
| 108LPDH | 108" | 60" Dual Wheel | 36" | 48½" | H | H | 20" | 89¾" | 1133 |
| 108LPD54V | 108" | 60" Dual Wheel | 36" | 54½" | V | V | 20" | 95¾" | 1169 |
| 108LPD54VH | 108" | 60" Dual Wheel | 36" | 54½" | V | H | 20" | 95¾" | 1169 |
| 108LPD54H | 108" | 60" Dual Wheel | 36" | 54½" | H | H | 20" | 95¾" | 1169 |

TOP OPENING COMPARTMENT MODELS

| | | | | | | | | | |
|-----------|------|------------------|-----|------|---|---|-----|------|------|
| 108VT | 108" | 60" Single Wheel | 38" | 48½" | V | V | 15" | 79¾" | 1229 |
| 108VHT | 108" | 60" Single Wheel | 38" | 48½" | V | H | 15" | 79¾" | 1229 |
| 108HT | 108" | 60" Single Wheel | 38" | 48½" | H | H | 15" | 79¾" | 1229 |
| 108DVT | 108" | 60" Dual Wheel | 38" | 48½" | V | V | 20" | 89¾" | 1347 |
| 108DVHT | 108" | 60" Dual Wheel | 38" | 48½" | V | H | 20" | 89¾" | 1347 |
| 108DHT | 108" | 60" Dual Wheel | 38" | 48½" | H | H | 20" | 89¾" | 1347 |
| 108D54VT | 108" | 60" Dual Wheel | 38" | 54½" | V | V | 20" | 95¾" | 1383 |
| 108D54VHT | 108" | 60" Dual Wheel | 38" | 54½" | V | H | 20" | 95¾" | 1383 |
| 108D54HT | 108" | 60" Dual Wheel | 38" | 54½" | H | H | 20" | 95¾" | 1383 |

Matches Or Exceeds Truck Manufacturers' Warranties

6 YEAR LIMITED WARRANTY
Hinges, Latches and Rust Through

3 YEAR LIMITED WARRANTY
All Other Body Components

In the interest of continuing product improvement, Omaha Standard Inc. reserves the right to modify, change or revise design and specifications and furnish product so altered without prior notice.

Standard Model Service Bodies include:

- Pickup style slam tailgate
- Stainless steel rotary paddle latches on all doors
- Automotive door seals in all compartments
- Four (4) trays for front vertical compartments
- One (1) tray for "V" style horizontal compartment
- Galvanized steel tray dividers
- One (1) shelf in each rear vertical compartment
- Spring loaded over-center door retainers on all full-sized vertical doors
- Cable retainers on small vertical doors on "H" configuration
- Cable retainers on curb side and street side horizontal doors
- Bodies are factory prime painted with gray epoxy electrocoat
- Universal "Quick Mount" mounting kit



108" Service Body shown on a dual rear wheel truck. Rear window protector is a popular option.



108" Service Body shown on a single rear wheel truck.



Made in the U.S.A.

The Omaha Standard 11' service bodies are designed for dual rear wheel chassis with 84" CA and have 20" deep compartments with 48½" or 54½" wide floors. The standard 132 body is 40" high, and top opening models are 38" high.

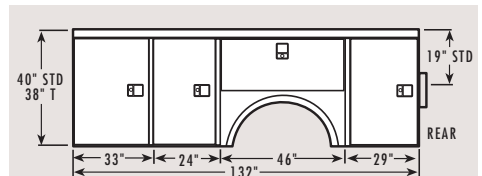

| "V" CONFIGURATION—CLEAR DOOR OPENINGS | | |
|---------------------------------------|-----------------|----------------------|
| COMPARTMENT | STANDARD | LOW PROFILE/TOP OPEN |
| Front | 27 ¾" w x 34" H | 27 ¾" w x 30" H |
| Intermediate | 19 ¾" w x 34" H | 19 ¾" w x 30" H |
| Horizontal | 43 ½" w x 14" H | 43 ½" w x 10" H |
| Rear | 23 ¾" w x 30" H | 23 ¾" w x 30" H |

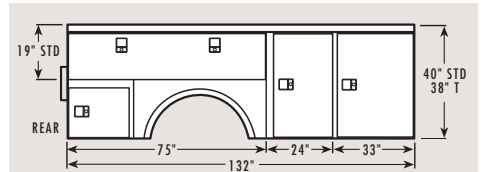

| "H" CONFIGURATION—CLEAR DOOR OPENINGS | | |
|---------------------------------------|-------------------|----------------------|
| COMPARTMENT | STANDARD | LOW PROFILE/TOP OPEN |
| Front | 27 ¾" w x 34" H | 27 ¾" w x 30" H |
| Intermediate | 19 ¾" w x 34" H | 19 ¾" w x 30" H |
| Horizontal | 71 ¾" w x 14" H | 71 ¾" w x 10" H |
| Bottom Rear | 23 ¾" w x 15 ¾" H | 23 ¾" w x 15 ¾" H |

"VH" Models are available in reverse configuration: i.e., "H" compartment configuration on the street side and "V" compartment configuration on the curb side. Specify "HV" when ordering. For compartment configurations other than shown, please consult the factory.

Standard Model Service Bodies include:

- Pickup style slam tailgate
- Stainless steel rotary paddle latches on all doors
- Automotive door seals in all compartments
- Four (4) trays for front vertical compartments
- One (1) tray for "V" style horizontal compartment
- Galvanized steel tray dividers
- One (1) shelf in each rear vertical compartment
- Spring loaded over-center door retainers on all full-sized vertical doors
- Cable retainers on small vertical doors on "H" configuration
- Cable retainers on curb side and street side horizontal doors
- Bodies are factory prime painted with gray epoxy electrocoat
- Universal "Quick Mount" mounting kit

| STANDARD MODELS | | | | | | | | | |
|-----------------|-------------|------------------|--------|-------------|--------------|-----------|------------------|---------------|-----------------------|
| MODEL | BODY LENGTH | CAB-TO AXLE (CA) | HEIGHT | FLOOR WIDTH | COMPARTMENTS | | EXT. COMP. DEPTH | OVERALL WIDTH | APPROX. WEIGHT (LBS.) |
| | | | | | STREET SIDE | CURB SIDE | | | |
| 132DV | 132" | 84" Dual Wheel | 40" | 48½" | V | V | 20" | 89¾" | 1403 |
| 132DVH | 132" | 84" Dual Wheel | 40" | 48½" | V | H | 20" | 89¾" | 1403 |
| 132DH | 132" | 84" Dual Wheel | 40" | 48½" | H | H | 20" | 89¾" | 1403 |
| 132D54V | 132" | 84" Dual Wheel | 40" | 54½" | V | V | 20" | 95¾" | 1466 |
| 132D54VH | 132" | 84" Dual Wheel | 40" | 54½" | V | H | 20" | 95¾" | 1466 |
| 132D54H | 132" | 84" Dual Wheel | 40" | 54½" | H | H | 20" | 95¾" | 1466 |

| TOP OPENING COMPARTMENT MODELS | | | | | | | | | |
|--------------------------------|-------------|------------------|--------|-------------|--------------|-----------|------------------|---------------|-----------------------|
| MODEL | BODY LENGTH | CAB-TO AXLE (CA) | HEIGHT | FLOOR WIDTH | COMPARTMENTS | | EXT. COMP. DEPTH | OVERALL WIDTH | APPROX. WEIGHT (LBS.) |
| | | | | | STREET SIDE | CURB SIDE | | | |
| 132DVT | 132" | 84" Dual Wheel | 38" | 48½" | V | V | 20" | 89¾" | 1572 |
| 132DVHT | 132" | 84" Dual Wheel | 38" | 48½" | V | H | 20" | 89¾" | 1572 |
| 132DHT | 132" | 84" Dual Wheel | 38" | 48½" | H | H | 20" | 89¾" | 1572 |
| 132D54VT | 132" | 84" Dual Wheel | 38" | 54½" | V | V | 20" | 95¾" | 1656 |
| 132D54VHT | 132" | 84" Dual Wheel | 38" | 54½" | V | H | 20" | 95¾" | 1656 |
| 132D54HT | 132" | 84" Dual Wheel | 38" | 54½" | H | H | 20" | 95¾" | 1656 |

END VIEWS OF 96", 108" AND 132" BODIES

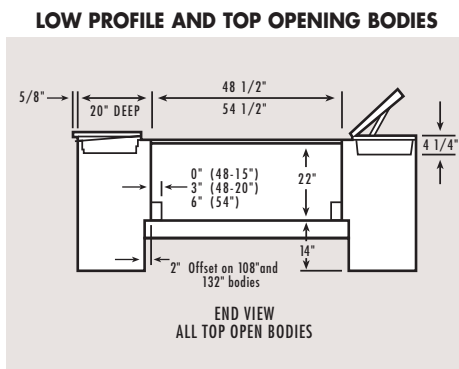
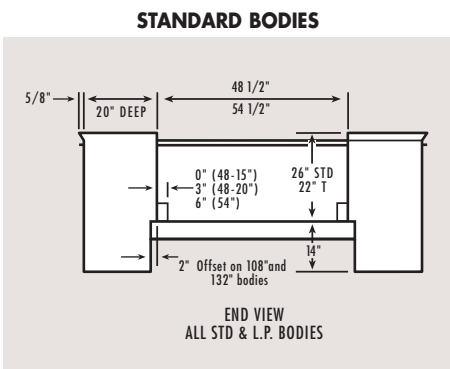

132" Service Body shown with rear window protector, a popular option.

Model 132 top opening compartment bodies are divided into two sections with two individual locking lids.



Matches Or Exceeds Truck Manufacturers' Warranties

| | | | |
|----------|---|----------|---------------------------|
| 6 | YEAR LIMITED WARRANTY | 3 | YEAR LIMITED WARRANTY |
| | Hinges, Latches, Trays and Rust Through | | All Other Body Components |

In the interest of continuing product improvement, Omaha Standard Inc. reserves the right to modify, change or revise design and specifications and furnish product so altered without prior notice.



Made in the U.S.A.

The Omaha Standard 156 and 168 service bodies were specifically designed to fit Ford Super Duty, GM 4500 and 5500 dual rear wheel chassis with 108" to 120" CA. These bodies have 20" deep compartments with 54½" wide floors. The standard body height is 40"; top opening compartment models are 42" high.

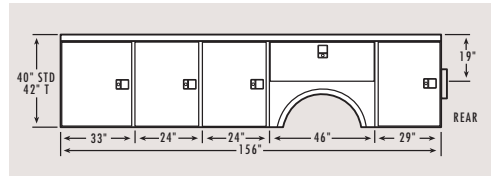

| 156 "V" CONFIGURATION-CLEAR DOOR OPENINGS | |
|---|------------------------|
| COMPARTMENT | STANDARD & TOP OPENING |
| Front | 27 ¼" w x 34" H |
| 1st Intermediate | 19 ¼" w x 34" H |
| 2nd Intermediate | 19 ¼" w x 34" H |
| Horizontal | 43 ½" w x 14" H |
| Rear | 23 ¼" w x 30" H |

| STANDARD MODELS | | | | | | | | | |
|-----------------|-------------|------------------|--------|-------------|--------------|-----------|------------------|---------------|-----------------------|
| MODEL | BODY LENGTH | CAB-TO AXLE (CA) | HEIGHT | FLOOR WIDTH | COMPARTMENTS | | EXT. COMP. DEPTH | OVERALL WIDTH | APPROX. WEIGHT (LBS.) |
| | | | | | STREET SIDE | CURB SIDE | | | |
| 156D54V | 156" | 108" Dual Wheel | 40" | 54½" | V | V | 20" | 95¾" | 1733 |
| 156D54VH | 156" | 108" Dual Wheel | 40" | 54½" | V | H | 20" | 95¾" | 1733 |
| 156D54H | 156" | 108" Dual Wheel | 40" | 54½" | H | H | 20" | 95¾" | 1733 |
| 168D54V | 168" | 120" Dual Wheel | 40" | 54½" | V | V | 20" | 95¾" | 1866 |
| 168D54VH | 168" | 120" Dual Wheel | 40" | 54½" | V | H | 20" | 95¾" | 1866 |
| 168D54H | 168" | 120" Dual Wheel | 40" | 54½" | H | H | 20" | 95¾" | 1866 |

| TOP OPENING COMPARTMENT MODELS | | | | | | | | | |
|--------------------------------|-------------|------------------|--------|-------------|-------------|-----------|------------------|---------------|-----------------------|
| MODEL | BODY LENGTH | CAB-TO AXLE (CA) | HEIGHT | FLOOR WIDTH | STREET SIDE | CURB SIDE | EXT. COMP. DEPTH | OVERALL WIDTH | APPROX. WEIGHT (LBS.) |
| 156D54VT | 156" | 108" Dual Wheel | 42" | 54½" | V | H | 20" | 95¾" | 2107 |
| 156D54VHT | 156" | 108" Dual Wheel | 42" | 54½" | V | H | 20" | 95¾" | 2107 |
| 156D54HT | 156" | 108" Dual Wheel | 42" | 54½" | H | H | 20" | 95¾" | 2107 |
| 168D54VT | 168" | 120" Dual Wheel | 42" | 54½" | V | V | 20" | 95¾" | 2240 |
| 168D54VHT | 168" | 120" Dual Wheel | 42" | 54½" | V | H | 20" | 95¾" | 2240 |
| 168D54HT | 168" | 120" Dual Wheel | 42" | 54½" | H | H | 20" | 95¾" | 2240 |

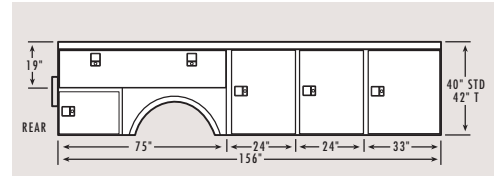

| 156 "H" CONFIGURATION-CLEAR DOOR OPENINGS | |
|---|------------------------|
| COMPARTMENT | STANDARD & TOP OPENING |
| Front | 27 ¼" w x 34" H |
| 1st Intermediate | 19 ¼" w x 34" H |
| 2nd Intermediate | 19 ¼" w x 34" H |
| Horizontal | 71 ¼" w x 14" H |
| Bottom Rear | 23 ¼" w x 15 ¼" H |

"VH" Models are available in reverse configuration: i.e., "H" compartment configuration on the street side and "V" compartment configuration on the curb side. Specify "HV" when ordering. For compartment configurations other than shown, please consult the factory

NOTE: Both 156/168 top opening compartments models have two top opening compartments per side, each approximately 65" long.

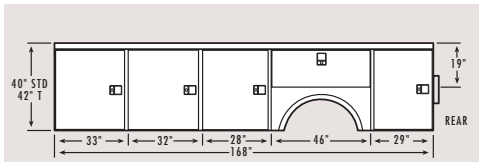

| 168 "V" CONFIGURATION-CLEAR DOOR OPENINGS | |
|---|------------------------|
| COMPARTMENT | STANDARD & TOP OPENING |
| Front | 27 ¼" w x 34" H |
| 1st Intermediate | 19 ¼" w x 34" H |
| 2nd Intermediate | 19 ¼" w x 34" H |
| Horizontal | 43 ½" w x 14" H |
| Rear | 23 ¼" w x 30" H |

Standard Model Service Bodies include:

- Pickup style slam tailgate
- Stainless steel rotary paddle latches on all doors
- Automotive door seals in all compartments
- Four (4) trays for front vertical compartments
- One (1) tray for "V" style horizontal compartment
- Galvanized steel tray dividers
- One (1) shelf in each rear vertical compartment
- Spring loaded over-center door retainers on all full-sized vertical doors
- Cable retainers on small vertical doors on "H" configuration
- Cable retainers on curb side and street side horizontal doors
- Bodies are factory prime painted with gray epoxy electrocoat
- Universal "Quick Mount" mounting kit

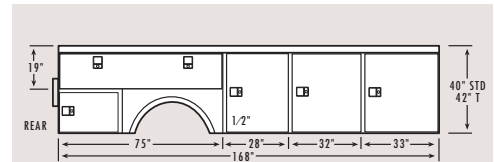

| 168 "H" CONFIGURATION-CLEAR DOOR OPENINGS | |
|---|------------------------|
| COMPARTMENT | STANDARD & TOP OPENING |
| Front | 27 ¼" w x 34" H |
| 1st Intermediate | 19 ¼" w x 34" H |
| 2nd Intermediate | 19 ¼" w x 34" H |
| Horizontal | 71 ¼" w x 14" H |
| Bottom Rear | 23 ¼" w x 15 ¼" H |

SERVICE BODIES FOR IMPORTED TRUCKS

IMPORTED CHASSIS -132DV-BS

The model 132DV-BS is an 11' service body that mounts on a dual wheel chassis with an 88.4 inch CA measurement. It is a vertical configuration on both sides. Compartments are designed to clear fuel tanks and battery boxes.

IMPORTED CHASSIS -132DV-NPR-CTR

The model 132DV-CTR is an 11' service body that mounts on a dual wheel chassis with an 88.4 inch CA measurement. It is designed to clear center mounted fuel tanks and provide clearance for air filters on intake air systems.

SERVICE BODY BUYERS GUIDE WORK SHEET

This worksheet is provided to help you in the decision making process with the many options and features available.

Body CA (Measurement from cab to center of rear axle) determines the body length.

| | | | | | | | |
|---|---|--|--|--|--|---|---|
| <input type="checkbox"/> 72V 37.6" CA Ford Ranger Only | <input type="checkbox"/> 76V 36.9" CA Dodge Only | <input type="checkbox"/> 80V <input type="checkbox"/> Chevy 42" CA <input type="checkbox"/> Ford 40" CA | <input type="checkbox"/> 96 56" CA Single or Dual Wheel Check box at right See Page 9 | <input type="checkbox"/> 108 60" CA Single or Dual Wheel Check box at right See Page 10 | <input type="checkbox"/> 132 84" CA Dual Wheel Only Total of 8 Compartments See Page 11 | <input type="checkbox"/> Single Wheel 48.5" Floor Width | <input type="checkbox"/> Dual Wheel 54.5" Floor Width |
| Single Wheel Vertical Configuration Only - See Page 8 | | | | | | | |

Compartments Select compartment style and configuration

STANDARD
LOW PROFILE
TOP OPEN

Standard
 Low Profile
 Top Opening

(See Pages 2&3)

Street Side

Curb Side

V Configuration

Street Side

Curb Side

H Configuration

Street Side

Curb Side

VH Configuration

Street Side

Curb Side

HV Configuration

| | Std. | Qty. | Front Compartment | | Intermediate Compartment (Model 132 Only) | | Horizontal Compartment | | Rear Compartment | |
|---|------|------|-------------------|------|--|------|------------------------|------|------------------|------|
| | | | Street | Curb | Street | Curb | Street | Curb | Street | Curb |
| Service Body Standard Equipment is indicated below. Use the quantity column to indicate the number of additional items ordered and use the compartment columns to indicate placement. | | | | | | | | | | |
| Divider Trays (2 in each front vertical compartment) | 2 | | | | | | | | | |
| Tray Dividers (20 standard) | 20 | | | | | | | | | |
| Shelves (1 shelf in each rear vertical compartment) | 1 | | | | | | | | | |
| Divider Tray (1 in horizontal compartment) | 1 | | | | | | | | | |
| Nested Slide Out Trays (150 or 250 lbs. capacity) Indicate number of trays & capacity (3, 4, or 5 tray sets) | | | | | | | | | | |
| Book Rack | | | | | | | | | | |
| Parts Cabinet | | | | | | | | | | |
| Dual Gas Bottle Holder | | | | | | | | | | |
| Drop Well For Gas Bottles w/Vents In Doors | | | | | | | | | | |
| Material Hooks | | | | | | | | | | |

- ### Latch Options
- Paddle Activated Rotary**
- Stainless Finish
- One-Point "T" Latch**
- Stainless Finish
- Three-Point "T" Latch**
- Stainless Finish
- Stylized Black Nylon Rotary Paddle Latch**
- Black Latch
- Note:** "T" Latch is standard equipment on all front raised compartment doors and dual vertical overlapping doors
- Electro-Mechanical Door Lock (EML)**
- Yes No (See Page 6)

- ### Master Locking System
- Yes No (See Page 6)
- ### Bumper Options
- Bumper Style**
- Standard
 - Hinged Recessed Cover
 - Recessed Ball Hitch Plate
 - Recessed
 - Recessed Lights
- Bumper Surface Textures**
- Standard Treadplate
 - Grip Strut
 - Grip Punch
- Note:** Chose one bumper style and one surface texture.
- (See Page 4)

- ### High Roof (See Page 5)
- Floor to Ceiling Heights**
- 54" 60" 72"
- HiRoof Options**
- Sliding Roof
 - Skylight Windows
 - Doors in sides for exterior access
 - Dome Lights with rear mounted switch
 - Extra interior shelving
 - Fully enclosed interior storage compartments with interior access doors.
 - Window guards for bulkhead and rear windows
 - Sliding glass in bulkhead window
 - Hot stick box with access door

- ### Treadplate Overlays
- Steel
 - Aluminum
 - Compartment Tops
 - Compartment Rear End Panels
 - Inside of Load Space
 - Inside Front
 - Scuff Plate
 - Front Compartment Rock Panel
 - Inside of Tailgate
- (See Page 6)
- This work sheet does not include every option available. If you have special needs, discuss them with your Omaha Standard Distributor to custom tailor a body that fits your specific needs.

- ### Ladder Racks
- Adjustable Overhead
 - Sloping Top Mounted
 - HiRoof Adjustable Overhead
 - HiRoof Side Mounted
 - Standard Compartment Top Rack
 - Ladder Rack Guide Rails
 - Ladder Rack Guide Rollers
 - Spring Loaded Hold Downs
 - Quick Removal Brackets
- (See Page 7)

Ask your distributor about these other quality products from Omaha Standard

The Omaha Standard quality equipment line includes e-coated platforms, stake bodies, contractor bodies, grain and livestock bodies. We also manufacture an outstanding line of low profile scissor, with or without subframes, and twin telescopic Olympic underbody hoists. Our equipment is sold and serviced by authorized Omaha Standard distributors who make it their business to see that you receive the finest equipment on the market and the best in installation and service.

"Badger" All Purpose Truck Bodies



Contractor Bodies



Stake Bodies



Solid Steel Stake Bodies



Aluminum "Badger" All Purpose Truck Bodies



Heavy Duty Platforms

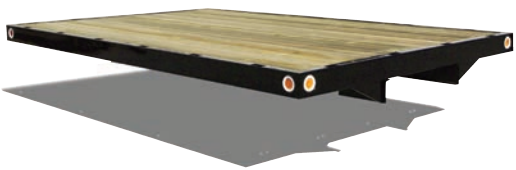

Super Duty Platforms



Low Profile Drop Hinge and Subframe Scissor Hoists



Matches Or Exceeds Truck Manufacturers' Warranties

| | |
|---|---|
| 6 YEAR LIMITED WARRANTY Hinges, Latches, Trays and Rust Through | 3 YEAR LIMITED WARRANTY All Other Body Components |
|---|---|

We Create Value...

Omaha Standard **e** COAT PROTECTED

3501 South 11th Street ■ Council Bluffs, Iowa 51501 USA
 Phone 712-328-7444 ■ 800-279-2201 ■ FAX 800-568-7444
 www.omahastd.com ■ e-mail: os@omahastd.com

In the interest of product improvement, Omaha Standard Inc. reserves the right to modify, change or revise design and specifications and furnish product so altered without prior notice.



Made in the U.S.A.



Sold and Serviced By:

Cliffside Body Corp.
 130 Broad Avenue
 Fairview, NJ 07022
 Phone: 201-945-3970
 www.CliffsideBody.com